

International Conference on Space Optics—ICSO 2018

Chania, Greece

9–12 October 2018

Edited by Zoran Sodnik, Nikos Karafolas, and Bruno Cugny



Research and Development of a Transportable Ground Optical Station in NICT

Yoshihiko Saito

Yasushi Munemasa

Hideki Takenaka

Hiroo Kunimori

et al.



icso proceedings



Research and Development of a Transportable Optical Ground Station in NICT

Yoshihiko Saito*^a, Yasushi Munemasa^a, Hideki Takenaka^a, Hiroo Kunimori^a, Dimitar Kolev^a, Alberto Carrasco-Casado^a, Yoshisada Koyama^a, Koichi Shiratama^a, Toshihiro Kubo-oka^a, Morio Toyoshima^a

^aNational Institute of Information and Communications Technology
4-2-1, Nukui-Kitamachi, Koganei, Tokyo, Japan 184-8795

ABSTRACT

In recent years, the necessity of satellite-to-ground optical communication has increased as a method for realizing higher-speed communications between satellites and the ground. However, one disadvantage of free-space optical (FSO) communication is the significant influence of the atmosphere. FSO communications cannot be utilized under certain atmospheric conditions, such as cloudy skies. One of the solutions to this problem is site diversity, which makes it possible to select a given ground station with better atmospheric conditions among a number of fixed ground stations. The other solution is to prepare a ground station that can be moved to a place with better atmospheric conditions. In this paper, we present the development of a transportable optical ground station currently being researched in NICT.

In order to be transportable, it is necessary to build a system capable of travelling on public roads, installable in every place, and ready to be loaded on relatively-light trucks. For this purpose, a realistic telescope diameter is about 30 cm at the maximum, capable of being set up quickly, and with a pointing accuracy of about 100 μ rad. In addition, it is necessary to prepare a fine-pointing optical system that performs tracking with about 1/10 of the pointing accuracy of the telescope. In this research, we will develop the base of the transportable optical ground station using the knowledge of mobile astronomical telescopes. With respect to tracking, we will develop a smaller and lighter fine-tracking system based on NICT's previous experience. If necessary, we plan to develop an adaptive-optics system for correcting atmospheric disturbances to improve the fiber-coupling efficiency of the communication laser beam.

Keywords: laser communication, optical ground station, transportable, site diversity

1. INTRODUCTION

In order to accelerate the communication speed between satellites and ground stations, free-space optical (FSO) communication will be a key technique. Therefore, the demand for FSO communication has greatly increased in the last few years. However, FSO communication between space and ground is affected by the atmosphere, for example, cloudy skies and atmospheric turbulence. One solution is site diversity; however, a large number of fixed stations are required to implement this approach successfully. In addition, in case of emergency, FSO communication at an arbitrary location would be required, since fixed ground stations cannot respond to this situation. Thus, we proceed to develop a transportable optical ground station (TOGS), which can be moved to a better place or to a location requiring a communication site with space and can deploy the functionality of an optical station. Development of TOGS was made by the Institute of Communications and Navigation of the German Aerospace Center (DLR) ^{1,2} and by NICT with a compact 2×2×4 m³ ground station transportable with a truck and capable of 40 Gbit/s lasercom with an aircraft³. Currently, NICT has started the development of another TOGS. In this paper, we introduce NICT's plan to develop this TOGS.

*saitoys@nict.go.jp; phone +811 42-327-5981; fax +81 42-327-6825;

2. CONCEPT OF TOGS

The basic concept of a TOGS is that it works as an optical ground station in any place. Main requirement is to be transportable by a vehicle that can travel on public roads in order to move from a standby place to a site where communication is required. The deployed location of the TOGS is assumed to be any place, and the setup of the TOGS should be completed as soon as possible at that location. To achieve this requirement, the telescope is preferably integrated with the transportation vehicle, and in order to handle the changing weather conditions, it is necessary to store the telescope and other instruments immediately in case of rain. To be able to establish stable communication links with aircrafts or satellites, we have to suppress the telescope vibrations. Based on this concept, we organize the requirements for TOGS.

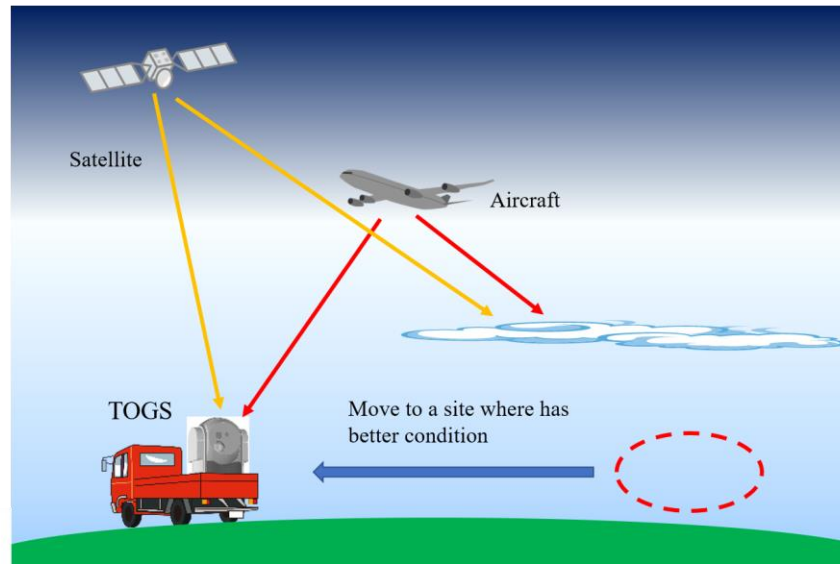

Figure 1. Concept of TOGS.

3. REQUIREMENTS FOR THE TOGS

The basic requirement is that the vehicle as well as the enclosure of TOGS can travel on a public road and can be operated by a regular truck driver's license in Japan. This is also a restriction in order to design the system. It is necessary to provide a vibration-absorbing function on the vehicle while moving so that the communication instruments are not affected. This function must work while moving on off-roads because the deployment location might be far from public roads. In order to deploy the ground station as soon as possible, we have to promptly complete the setup of the telescope for pointing to the aircraft or satellite. Therefore, the telescope must be integrated within the vehicle, and the vehicle must have a function to open the roof of the vehicle in order to receive the optical beam from the aircraft or satellite. The field of view of the telescope needs to have an arbitrary angle of elevation beyond the horizon with respect to all azimuthal directions. We require that the telescope installed in the vehicle has the largest aperture possible.

For the stability of optical communication, the vehicle must have a mechanism to fix vibrations. It is necessary to provide a mechanism to obtain the location information of the ground station deployment, and to calculate the relationship between the direction of the telescope and the position on the celestial sphere for setup of the TOGS. We require an optical system that efficiently transmits the photons collected by the telescope to the receiver, and an interface with an external power supply because an internal power supply would generate vibrations. It is also necessary to provide an interface to an external communication network. These requirements are summarized in the tables 1 and 2. We prepared the first specification of transportable optical ground station according to these requirements.

4. REQUIRED SPECIFICATION OF TOGS

In order to determine the specifications according to the requirements, we divided the elements of this development into three components: the vehicle, the telescope, and the fine-pointing optics. The vehicle and its additional parts provide the base of a system that transports a communication device without instruments failure and can be quickly deployed at any destination. The telescope must be able to efficiently collect the photons propagating in space and to provide a pointing accuracy sufficient to acquire a light source into the field of view of the telescope. Since the pointing accuracy of the telescope is not enough to stabilize the communication, we must install the fine-pointing optics that enable to stabilize the signal intensity which is inputted to the receiver.

4.1. Vehicle

The specifications of the vehicle are as shown in Table 1. An 8-ton truck is a realistic assumption for the maximum size allowable to travel on public roads with a regular license in Japan. Air suspension during the transportation is required, such as a vibration-absorbing mechanism. An outrigger mechanism is also required to fix the vehicle to the ground of a deployed place as an additional equipment for the vehicle. The pedestal on which the telescope is installed needs to be equipped with a vibration-isolation mechanism in the floor of the vehicle. The fine-pointing optics also needs to be covered by this vibration-isolation system, because this optics must be fixed to the telescope. A retractable roof above the telescope is required as well. In our design, while only three directions will be available for communications, we can arrange the vehicle towards any arbitrary orientation. Therefore, we will be able to adjust the direction of the vehicle in accordance to the orbit of the spacecraft. In addition, space for installing the receiver and its control instruments is also required, as well as space for the maintenance. Currently, the design of the vehicle is assumed to be like the one shown in figure 2.

Table 1. Required Specification of the vehicle.

Item	Required specification
Weight	< 8,000 kg
Size (vehicle)	8.5(L) × 2.4(W) × 3.5(H) m
Size (enclosure)	6.0(L) × 2.0(W) × 2.3(H) m
Stabilize system	<ul style="list-style-type: none"> • Air suspension for all wheels • Base isolation mount for telescope and optical bench
Other additional parts	<ul style="list-style-type: none"> • Sliding roof • Hydraulic jack • Leveling system of telescope and optical bench • Two air-conditioner systems (for internal and external power source) • Connector panel for external power source

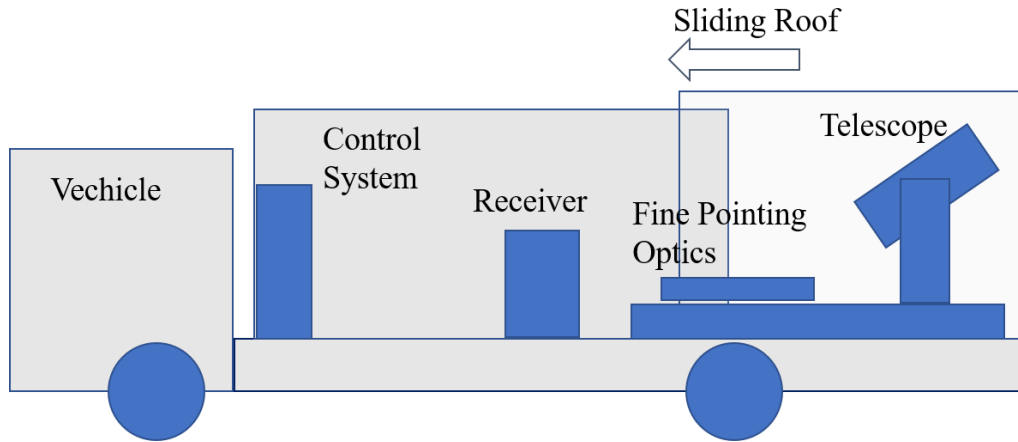

Figure 2. Vehicle and mounted components.

4.2. Telescope

The required specifications of the telescope are as shown in Table 2. The diameter of the telescope should be 30 cm, considering the vehicle size and load bearing capacity. We adopted an azimuth mount for the telescope in order to enable fixing the vehicle in any arbitrarily orientation. Since the optical bench for the fine-pointing optics is fixed to the vehicle, the beam for communication is required to transmit from the coudé path to the optical bench. In order to secure the pointing accuracy of the telescope, we will first acquire the position information of the ground station, and then perform a pointing analysis by using stars to improve the accuracy of the orientation.

Table 2. Required specifications of the telescope.

Item	Required specification
Type	Reflecting telescope
Mirror material	Aluminum
Main mirror diameter	30 cm
Mount	Azimuth mount
Focus	Coudé
Pointing accuracy	50 μ rad
Tracking speed	0.3 deg/sec
Weight	300 kg

4.3. Fine-pointing optics

The fine-pointing optics should stabilize the intensity of light supplied from the telescope to the receiver. This optical system is shown in figure 3. The fine-pointing optics consist of a sensor for measuring positional deviation and a mirror for correcting the deviation. The measurement of positional deviation is performed by a sensor dividing the wavefront into four parts. The mirror that controls the tip-tilt is operated to correct the positional shift. As mentioned

above, the optical bench on which the fine-pointing optics is constructed is fixed to the vehicle. Therefore, these optics should be implemented considering to prevent any misalignment of the optics by vibration while moving.

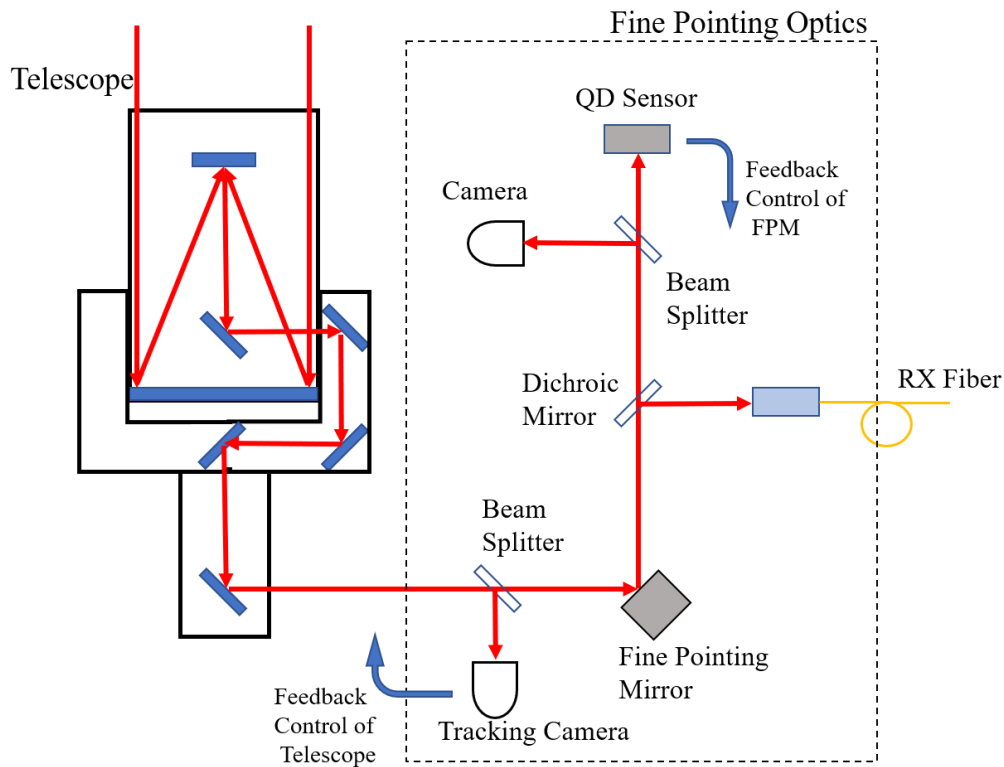

Figure 3. Fine-pointing optics of TOGS.

5. DISCUSSION

In this development, we have to investigate how to develop a system that can be set up quickly, and we have to evaluate the vibration resistance of the whole system. The required time for system setup must be as short as possible to reduce the risk of weather or atmospheric conditions changes meanwhile. The problem to be solved is how to quickly fix the station on the ground, the horizontal leveling, and the pointing analysis of the telescope. In particular, the pointing analysis using stellar coordinates cannot be set up during the day time. We need to investigate other methods to quickly point the telescope. Furthermore, the fine-pointing optics is an important component to achieve the required accuracy. We will also consider installing adaptive optics to compensate the influence of the atmospheric turbulence on the optical system.

ACKNOWLEDGEMENT

This work is a part of “Research and Development of the Quantum Cryptography Technology for Satellite Communications” in “Research and Development of Information and Communications Technology” of Ministry of Internal Affairs and Communication (MIC), Japan and this work is supported by MIC.

REFERENCES

- [1] Shrestha, A., and Brechtelsbauer, M., "Transportable optical ground station for high-speed free-space laser communication," Proc. SPIE 8517, 851706 (2012).
- [2] E. Fischer et al., "Development, Integration and Test of a Transportable Adaptive Optical Ground Station," ICSOS 2012, New Orleans, Louisiana, U.S. (2015).
- [3] M. Toyoshima et al., "Terrestrial Free-Space Optical Communications Network Testbed: INNOVA," Proc. of International Conference on Space Optical Systems and Applications (ICSOS) 2014.